

CANDIDATE EXAM PAPER

CANDIDATE NUMBER: _____

CEE1 – Electrical engineering applied to coal mines

**ELECTRICAL ENGINEERING MANAGER OF UNDERGROUND COAL MINES
EXAMINATION FOR CERTIFICATE OF COMPETENCE**

Legislation to be assessed:

Unless otherwise stated all references to Act and Regulations are to:

Work Health and Safety Act 2011
Work Health and Safety Regulation 2017
Work Health and Safety (Mines and Petroleum Sites) Act 2013
Work Health and Safety (Mines and Petroleum Sites) Regulation 2014
Explosives Act 2003
Explosives Regulation 2013
and
Australian/New Zealand Standards (the standards)

This Examination is held in the following location:

Region: New South Wales

Venue: Tocal College

Room: Glendarra 2 conference room

Start date/time: 28 Sep 2022 08:50:00

CEE1 – Electrical engineering applied to coal mines

INSTRUCTIONS TO CANDIDATES

Q #	Marks	Available Marks	Marked by <i>Initials</i>	Summary comments to justify
1		10		
2		10		
3		10		
4		10		
5		10		
6		10		
Paper Total		60		<i>Marks checked by:</i>

EXAM BOOKLET

Answers are to be written in the allocated spaces
within this booklet ONLY

Answers must be written in pen however,
drawings may be completed in pencil

This booklet is not to be altered in any way,
pages are not to be added or removed

Additional space is provided at the end of the paper.
Please label which question the answer relates to.

Some questions in this paper are marked as essential and that candidates must get X out of 10 to pass the question. Failure to achieve this mark in each of the nominated questions will result in the candidate not passing the paper

Question 1

Operational decision making and initiative

- Referring to evidence and objective information when establishing standards and procedures
- Taking actions prescribed under WHS laws when safety concerns or risks have been identified, where appropriate

Electric Shock (Essential)

Candidates must get 7 out of 10 to pass this question

You are the Electrical Engineering Manager at a mine and have been notified that a worker at your mine has received an electric shock whilst in contact with a 1000Vac Continuous Miner.

The following information has been gained from your investigation:

- Operator received a shock while contacting the frame of the Continuous Miner
- The supply to the equipment has tripped on earth leakage protection
- The machine event logs identified that a cutter head motor was starting at the time of the incident
- The motor supply cable has been found to be damaged and worn through
- The protective earth was intact and continuity from the frame of the equipment to the source of supply and was measured at 1.5 Ohms
- The estimated human body resistance path to earth is 1000 Ohms
- The equipment is supplied from a 5A earth fault limited system.



a) Draw an equivalent circuit showing the electric shock current flow paths through the equipment and worker (human body) and via the protective earth. (2 Marks)

b) As defined in AS/NZS 3000 Wiring Rules, nominate what form of contact the worker made and what is the definition of: (3 Marks)

- “Direct contact”
- “Indirect contact”

c) Using the information gained from the investigation, calculate the current flow through the human body. Show all working (4 Marks)

d) What clause would you notify this incident under, and what are the obligations under the Work Health and Safety (Mines and Petroleum Sites) Act and Regulation, specific to this electric shock incident? (1 Mark)

Question 2

Collaboration

- Identifying key internal and external stakeholders, and collaborating through participation in consultation
- Providing supervision on how risks are managed as per the relevant control plan, standards and legislation

Unplanned movement

You are the Manager of Electrical Engineering at an underground mine. You have been contacted by the control room operator that, “we think we have had an unplanned movement (UPM) of a continuous miner in 101 panel. The conveyor boom continued to swing to the right-hand side”.

a) What would be your initial steps after receiving this information (3 Marks)

b) Draft the steps that your investigation plan would outline and any key areas you would investigate? (3 Marks)

c) Once it's been confirmed that it was an UPM and the scene released, who would you involve in the incident investigation and why? (2 Marks)

d) From your investigation you are unable to establish a root cause, before putting the machine back in to service. What further controls would you implement? (2 Marks)

Question 3

Technical knowledge and skills

- Mining and WHS systems

Cable construction

AS/NZS 1802 Electric cables—Reeling and trailing—for underground coal mining

Outlines cables used for underground coal operations in reeling and trailing applications are designed to be “fit for purpose” for their duty in a particularly harsh environment.

a) For a “type 275.1 Trailing Cable”, what does the “.1” indicate? (1 Mark)

b) Draw a typical cross-sectional diagram of a “type 275.1 Trailing Cable” and identify three (3) critical design features of the cable’s internal cores, insulation and screening. (3 Marks)

c) Describe the two of the primary design features of the cable construction and summarise the electrical engineering reasons for the particular feature. (2 Marks)

d) List four of the eight pre-repair tests which need to be carried out on every mining cable when sent to a licensed repair workshop? (2 Marks)

e) What equipment would you typically find this cable installed on, in an underground operation? (1 Mark)

f) What is meant by the term 'symmetrical' with respect to cables and why is this important? (1 Mark)

Question 4

Driven by safety and integrity

- Providing instruction and guidance to others on how to comply to existing legislation, standards and procedure
- Identifying situations where legislation and safety standards are compromised

Winder

You are the Electrical engineering manager of an Underground mine, during a statutory inspection of a vertical shaft winder, a supervisor found a set of pneumatic gates open at the underground platform. The winder cage was docked at the surface platform leaving access to the exposed shaft at the underground platform.

a) Would this incident be notifiable to the Regulator? (1 Mark)

b) If so, explain under what clause and why? (1 Mark)

c) What two design documents would you reference to assist in the review of this incident. (2 Marks)

Assuming that the incident investigation identified concerns with the adequacy of the platform gate design then:

d) Nominated four key people you would involve in the design review of the electrical safeguards? (1 Mark)

e) List 3 documents you would need to consider/review for potential design changes? (2 Marks)

f) List 2 control measures that could be introduced to minimise the risk of the gates failing prior to any design changes being undertaken. (1 Mark)

g) List 3 control measures that should prevent this type of failure mode in the future. (2 Marks)

Question 5

Technical knowledge and skills

- Mining and WHS systems
- Legislation

Lightning Management Underground (Essential)

Candidates must get 6 out of 10 to pass this question

The earthing configuration below shows three distinct earthing systems that are isolated from one another. The three earthing systems are the 'Network Earth' (NE) which includes the incoming 66kV substations 0 and 1, the 'Mine Surface Earth' (MSE) which includes 11kV substation 2 and all surface electrical supplies and infrastructure, and the 'Mine Underground Earth' (MUE) which includes all electrical supplies and infrastructure underground.

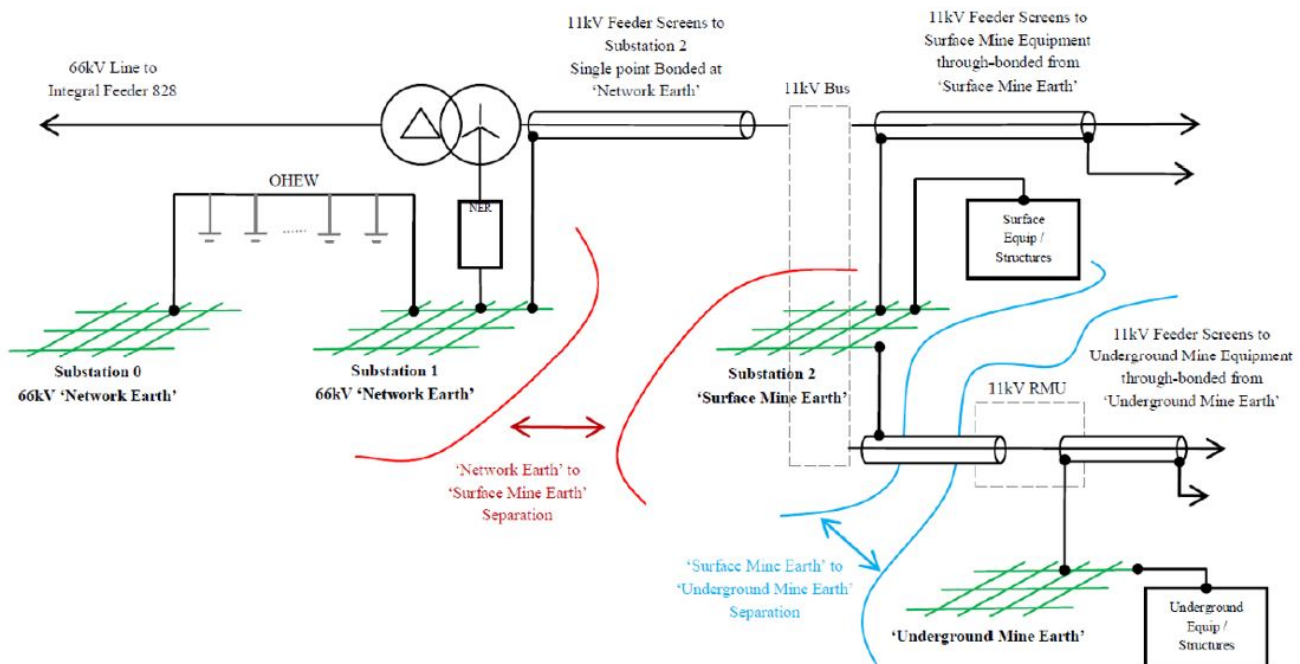

a) What is the purpose of the 'Underground Mine Earth Separation'? (2 Marks)

b) List 4 ways that the separation could become compromised. (2 Marks)

c) For each of the issues identified in part b above, list the controls you would consider and how they would be managed. (2 Marks)

d) How would you control the risks relating to the use of conductive lined bore cases at your site and where would this information be captured in your sites Health and Safety Management system? (4 Marks)

Question 6

Operational decision making and initiative

- Providing advice on implementation of standards, processes and systems, and verifying implementation and compliance, and on how risks should be managed

Fault Calculate (Essential)

Candidates must get 6 out of 10 to pass this question

You are the Electrical Engineering Manager at a mining operation that wishes to expand into a new area. You are using existing mine infrastructure for the construction phase of the project. The infrastructure consists of a switchyard containing three transformers that feed two different areas of the lease by means of a buried service.

The incoming supply is 11kV with a fault level nominated by the Network Service Provider at 150MVA. The switchyard is arranged such that a maximum of two transformer may be taken out of service on maintenance days. The two existing feeders will be used to support Mining Infrastructure Areas.

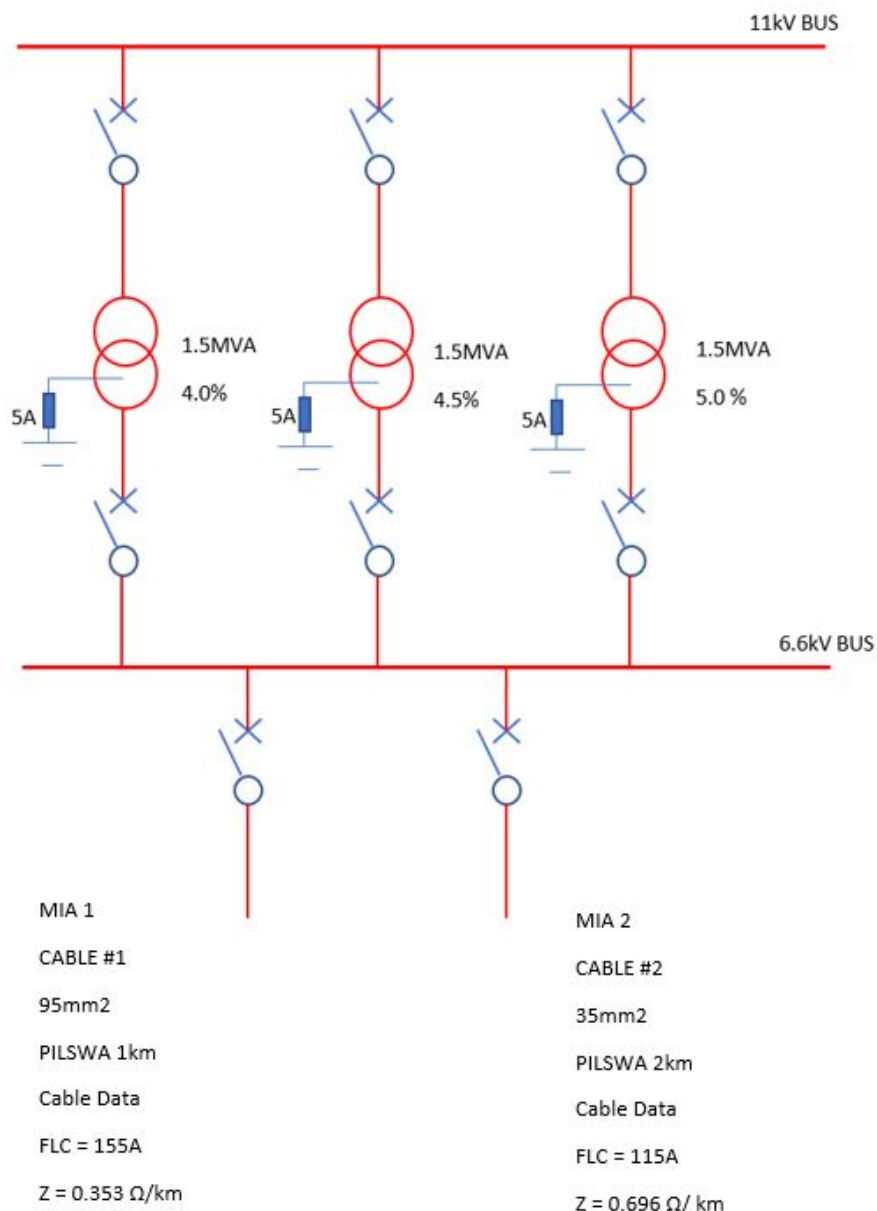

a) Assuming all Circuit Breakers are closed, what is the maximum prospective earth fault. (1 Mark)

b) What is the effect on the maximum prospective earth fault if one of the transformers is taken out of service for maintenance. (1 Mark)

c) Using any calculation method you are comfortable with, calculate the fault level at the 6.6kV surface busbar with all transformers online. (3 Marks).

d) Calculate the maximum load in MVA that can be utilised without overloading any of the transformers. (2 Marks)

e) Nominate the protection current settings for MIA Feeder #2 CB ANSI Code 51P ANSI Code 50P (2 Marks)

Note: ANSI 51P is the code for Timed Overcurrent.

ANSI 50P is the code for Instantaneous Overcurrent.

f) Justify your answer. (1 Mark)

End of Document

CANDIDATE EXAM PAPER

CANDIDATE NUMBER: _____

CEE2 – Legislation and Australian Standards applicable to underground mines

**ELECTRICAL ENGINEERING MANAGER OF UNDERGROUND COAL MINES
EXAMINATION FOR CERTIFICATE OF COMPETENCE**

Legislation to be assessed:

Unless otherwise stated all references to Act and Regulations are to:

*Work Health and Safety Act 2011
Work Health and Safety Regulation 2017
Work Health and Safety (Mines and Petroleum Sites) Act 2013
Work Health and Safety (Mines and Petroleum Sites) Regulation 2014
Explosives Act 2003
Explosives Regulation 2013
and
Australian/New Zealand Standards (the standards)*

This Examination is held in the following location:

Region: New South Wales

Venue: Tocal College

Room: Glendarra 2 conference room

Start date/time: 28 Sep 2022 12:50:00

CEE2 – Legislation and Australian Standards applicable to underground mines

INSTRUCTIONS TO CANDIDATES

Q #	Marks	Available Marks	Marked by <i>Initials</i>	Summary comments to justify
1		10		
2		10		
3		10		
4		10		
5		10		
6		10		
7		10		
8		10		
9		10		
10		10		
11		10		
12		10		
Paper Total		120		<i>Marks checked by:</i>

EXAM BOOKLET

Answers are to be written in the allocated spaces
within this booklet ONLY

Answers must be written in pen however,
drawings may be completed in pencil

This booklet is not to be altered in any way,
pages are not to be added or removed

Additional space is provided at the end of the paper.
Please label which question the answer relates to.

Some questions in this paper are marked as essential and that candidates must get X out of 10 to pass the question. Failure to achieve this mark in each of the nominated questions will result in the candidate not passing the paper

Question 1

Situational Awareness and Risk Assessment

- Reviewing by measuring the effectiveness of the relevant standards and procedures
- Verifying relevant standards and procedures in principal hazards management plans and principal control plans

AS/NZS 2290.1 – Electrical equipment for coal mines (introduction, inspection and maintenance)

AS/NZS2290.1 *Electrical equipment for coal mines (introduction, inspection and maintenance (the **standard**)* discusses the requirements for pre-overhaul audits of explosion protected equipment and states that these audits are to be carried out by a competent person.

a) The competent person shall have the competencies to conduct, detailed inspections and overhaul/repair of explosion protected equipment. What is the standard or scheme that is used to govern these competencies? (2 Marks)

b) The standard gives three requirements that shall be followed when repairs to in-service Flameproof equipment is undertaken. List two of the three requirements. (2 Marks)

i

ii

c) As nominated in AS/NZS2290.1 – When explosion protected equipment has been in storage prior to installation its current condition shall be assessed. What are the two key points that need to be assessed? (2 Marks)

i

ii

d) When completing an assessment for explosion protected equipment that has been in storage, prior to installation - what is the assessment used to determine? (1 Mark)

e) The standard outlines 4 documents that are required to be obtained where the equipment has been kept in storage prior to going into service, list 3. (3 Marks)

i

ii

iii

Question 2

Situational Awareness and Risk Assessment

- Monitoring by obtaining data, information, and evaluating audit outcomes to verify compliance with standards and legislation

Work Health and safety (mines and petroleum) Regulations Schedule 2 Principal control plans– matters to be addressed (Clause 26)

Electrical engineering control plan

a) *Work Health and safety (mines and petroleum) Regulations requires: the operator of a mine or petroleum site must, in preparing an electrical engineering control plan, take the following into account in determining the means by which the operator will manage the risks to health and safety from electricity at the mine or petroleum site:*

WHS (MPS) Regulation Schedule 2 Principal control plan (3) Electrical engineering control plan nominates four points. List 3 of these requirements. (3 Marks)

i

ii

iii

b) *Schedule 2 Principal control plan (3) Electrical engineering control plan. An electrical engineering control plan must set out the control measures for the following risks to health and safety associated with electricity at the mine or petroleum site taking into account the matters set out in subclause (3):*

List four of these requirements. (4 Marks)

i

ii

iii

iv

c) *Work Health and safety (mines and petroleum) Regulations Cl 10-Review of control measures states:*

A person conducting a business or undertaking at a mine or petroleum site must review and as necessary revise control measures implemented under clause 9 in the following circumstances

List 3 of the circumstances outlined in regulations. (3 Marks)

i

ii

iii

Question 3

Operational decision making and initiative

- Considering available evidence and objective information when monitoring and evaluating standards and procedures, as well as audit results, health and safety performance outcomes and remedial actions

Work Health and safety (mines and petroleum) Regulations–Clause 79 Exceptions to explosion-protection requirements

The WHS(MPS) Regulation clause 78 (1) requires that electrical plant used in the hazardous zone must be explosion protected.

Clause 79 (1) documents, despite the requirements of clause 78 (1), portable electrical plant may be used in the hazardous zone of an underground coal mine if:

a) List 4 of the 5 requirements referred to in Clause 79: (4 Marks)

i

ii

iii

iv

The WHS(MPS) Regulation clause 78 (1) requires that electrical plant used in the hazardous zone must be explosion protected. Despite the requirements of clause 78 (1), insulation test instruments may be used in the hazardous zone of an underground coal mine if

Clause 79 (3) documents how insulation test instruments may be used in the hazardous zone of an underground coal mine if:

b) Outline the requirement to use insulation test instruments - Clause 79. (1 Mark)

The WHS(MPS) Regulation clause 78 (1) requires that electrical plant used in the hazardous zone must be explosion protected.

Clause 78 (9) **certificate of conformity** means a certificate of conformity issued under...

c) List the 3 schemes documented in this clause. (3 Marks)

i

ii

iii

d) Clause 78 (9) Departmental approval plant (MDA) outlines 2 requirements for continued use of explosion protected apparatus. List both requirements. (2 Marks)

i

ii

Question 4

Driven by safety and integrity

- Setting, upholding and monitoring the health and safety expectations by developing, supervising and following the safety management system

AS/NZS 60079.25 Explosive Atmospheres - Intrinsically Safe electrical systems

AS/NZS 60079.25 Intrinsically safe electrical systems Cl 12 - Assessment of an intrinsically safe system

a) The compliance of an intrinsically safe system shall be demonstrated by consideration of the following:

List 5 of the 8 considerations. (5 Marks)

i

ii

iii

iv

v

AS/NZS 60079.11 – Equipment protected by Intrinsic safety “I”

b) In your own words, define the following terms with regards to Intrinsic Safety. (1 Mark each)

i. Intrinsic safety “I”

ii. Simple apparatus

iii. Associated apparatus

iv. Intrinsically safe circuit

v. Intrinsically safe apparatus

Question 5

Responsiveness to change

- Reviewing standards, processes and the SMS to instituting change where necessary, as per changes in conditions.

Electrical Engineer Statutory Function (Essential)

Candidates must get 6 out of 10 to pass this question

Work Health Safety (Mines and Petroleum Sites) Regulation 2014 Schedule 10 *Statutory Functions at mines Part 2 Underground coal mines*. Nominates the statutory function requirements

a) Electrical Engineering Manager: (5 Marks)

i

ii

b) The requirement for nomination to exercise the statutory functions is that the individual nominated must: (2 Marks)

c) Clause 14 of Schedule 10 discusses *Qualified electrical tradesperson*. Give your understanding of what the statutory function is of a qualified electrical tradesperson. (3 Marks)

Question 6

Driven by safety and integrity

- Setting, upholding and monitoring the health and safety expectations by developing, supervising and following the safety management system

AS/NZS IEC 60079 (Essential)

Candidates must get 7 out of 10 answers correct

These multiply choice questions relate to AS/NZS IEC 60079 Series Explosion protection. Circle the correct answer to the following question. (1 Mark each)

a) Which number depicted represents 'L'?

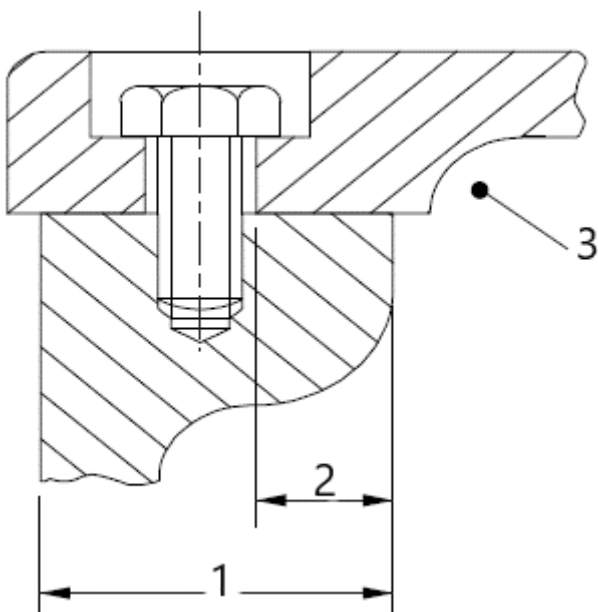

- 1
- 2
- 3
- None

b) Results of an ignition, in a compartment or subdivision of an enclosure, of a gas mixture pre-compressed, for example, due to a primary ignition in another compartment or subdivision.

The above description is referring to:

- i. Pressure Piling
- ii. Internal Combustion
- iii. Capacitive Coupling
- iv. Harmonic Resonance

c) **Entries for flameproof enclosures:** internal metric threads shall be a tolerance class of ____ or better.

- i. 5G
- ii. 6H
- iii. 6G
- iv. 8H

d) **Entries for flameproof enclosures:** external metric threads shall have a threaded part of at least 8 mm in length and at least ____ full threads.

- i. 5
- ii. 6
- iii. 8
- iv. 10

e) What document outlines Classification of areas Explosive dust atmospheres?

- i. AS/NZS 3000:2018, Section 7.7.2.1
- ii. Work Health and Safety Act 2011
- iii. AS/NZS 60079.10.2
- iv. Work Health and Safety (Mines and Petroleum Sites) Act 2013

f) Which of these Australian Standards is relevant for Classification of areas - Explosive gas atmospheres?

- i. AS/NZS 60079.1
- ii. AS/NZS 7000
- iii. AS/NZS 3012
- iv. AS/NZS 60079.10.1

g) **Limitation of maximum surface temperature, Group I electrical equipment**, maximum surface temperature shall not exceed ____ on any surface where coal dust can form a layer.

- i. 100 °C
- ii. 150 °C
- iii. 200 °C
- iv. 250 °C

h) **Limitation of maximum surface temperature, Group I electrical equipment**, maximum surface temperature shall not exceed_____ where coal dust is not likely to form a layer.

- i. 450 °C
- ii. 500 °C
- iii. 650 °C
- iv. 700 °C

i) Of the options provided, which Australian Standard is relevant for Equipment protection by intrinsic safety 'i'?

i. AS/NZS 60079.11

ii. AS/NZS 60079.1

iii. AS/NZS 7000

iv. AS/NZS 3012

j) Explosive atmospheres: Which of these Australian Standards is relevant for Electrical installations inspection and maintenance?

i. AS/NZS 60079.11

ii. AS/NZS 60974.11

iii. AS/NZS 3760

iv. AS/NZS 60079.17

Question 7

Situational Awareness and Risk Assessment

- Assisting or participating in risk assessment processes

Bow Tie Analysis (Essential)

Candidates must get 5 out of 10 to pass this question

Bowtie Risk Assessment (RA) is a methodology that allows risk to be evaluated in terms of multiple scenarios surrounding an unwanted situation and presents a holistic picture of the overall risk which is easy to communicate.

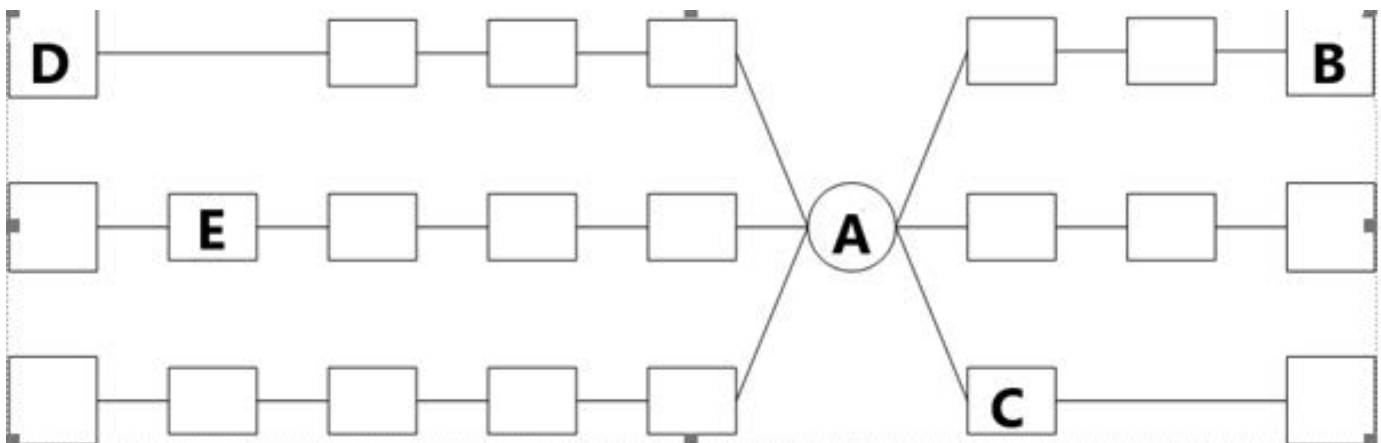

a) Using the Bow Tie diagram above, Identify the elements using the list below. (2.5 Marks)

Recovery Control

Consequences

Preventative Control

Unwanted Event

Threat

b) Define the term “critical control”. (2 Marks)

c) Identify the controls that you would implement to prevent the likelihood of electric shock to a person that is completing electrical maintenance on a 66kv/11kv switch yard. (3.5 Marks)

d) Which of the controls that you have identified in part c above would be considered critical? (2 Marks)

Question 8

Effective Communication

- Explaining the results of their analysis of data, information and/or audit outcomes

Emergency Preparedness

The Work Health and Safety (Mines and Petroleum Site) Regulation 2014, *Part 5 Survey plans and mine plans. Clause 122 Survey plan* include **certain items of electrical plant**.

a) Nominate the electrical items of plant that are required to be included in mine plans. (2 Marks)

The Work Health and Safety (Mines and Petroleum Site) Regulation 2014, *Clause 73 Gas Monitoring* requires the mine operator of an underground coal mine must ensure certain requirements are in place regarding gas monitors.

b) Describe the legislated requirements for fixed devices used to determine or monitor the presence of gas at an underground coal mine. (5 Marks)

c) The Work Health and Safety (Mines and Petroleum Site) Regulation 2014 *clause 72 Control and monitoring of methane levels* nominates that the mine operator of an underground coal mine must ensure that each face at which longwall, shortwall or miniwall mining operations are taking place is equipped with a continuous methane monitor that:

the supply to the face be removed if the concentration of methane in the general body of air is _____ by volume or greater at the face.

Specify the % of methane. (1 Mark)

d) The Work Health and Safety (Mines and Petroleum Site) Regulation 2014 clause 72 *Control and monitoring of methane levels,*

At what percentage by volume of methane does the regulation require the supply of power to the removed from face machine if the concentration of methane in the air close to the heads of the face machine (continuous miner)? (1 Mark)

e) *What is the explosive range of methane found in coal mines? (1 Mark)*

Question 9

Technical knowledge and skills

- Mining and WHS systems
- Legislation

Intrinsic Safety (Essential)

Candidates must get 6 out of 10 to pass this question

In reference to AS/NZS 60079.25 *Intrinsically safe electrical systems contain specific requirements for construction and assessment of I.S systems.*

a) Connect the devices below (*Figure 1*) to form a simple intrinsically safe circuit. (3 Marks)

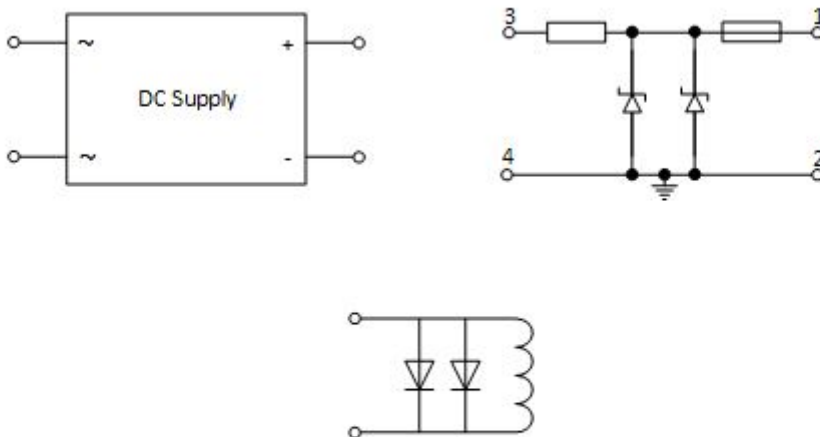

Figure 1

b) Describe three of the five requirements nominated in clause 82 of the Work Health & Safety (Mines & Petroleum site) Regulation you would include for the testing of intrinsically safe circuits in the hazardous zone. (2 Marks)

c) When determining the suitability of a cable for use in an intrinsically safe circuit, list three of the five cable parameters nominated in the standard. (1 Mark)

d) Parameter matching and Ex marking. (2 Marks)

Circle correct answer:

i. Which certification would be suitable for the longwall face?

- Ex e d m (ib) I IP66 T5
- Ex db [ia Ga] IIC Gb
- Ex e d m (ia) I IP66 T3
- Ex ma IIC T4 Da

Note: Temperature Classification from AS/NZS 60079.10.1 Explosive atmospheres, Part 10.1: Classification of areas — Explosive gas atmospheres

Class	Temperature (Celsius)
T1	450
T2	300
T3	300
T4	135
T5	100
T6	85

ii. Which combination of certified components maintain an intrinsically safe system?

- Vo-12.1V, Co-1 μ F, Lo-0.0 μ H & Vi-11.0V, Ci-1.1 μ F, Li-0.01 μ H
- Vo-12.1V, Co-1 μ F, Lo-10.0 μ H & Vi-12.8V, Ci-0.1 μ F, Li-0.001 μ H
- Vo-12.1V, Co-1 μ F, Lo-0.0 μ H & Vi-12.1V, Ci-0.4 μ F, Li-0.0 μ H
- Vo-12.1V, Co-1 μ F, Lo-0.0 μ H & Vi-12.8V, Ci-1.1 μ F, Li-0.10 μ H

e) Explain the significance of Ex equipment certifications marked with the symbol "U" and symbol "X". (2 Marks)

"U"

"X"

Question 10

Effective Communication

- Explaining the results of their analysis of data, information and/or audit outcomes

(Essential)

Candidates must get 6 out of 10 to pass this question

AS/NZS 3800:2020 Electrical equipment for explosive atmospheres—Repair and overhaul gives instruction, principles of a technical nature on the repair, overhaul reclamation and modification of equipment designed for use in explosive atmospheres.

a) What are the two (2) key requirements a repair workshop must satisfy before it can overhaul explosion protected equipment for NSW coal mines? (1 Mark)

b) Within the appendixes of this standard *AS3800*, the terms *Normative* and *Informative* are used. What is the meaning of these with respect to the standard? (2 Marks)

i. Normative:

ii. Informative:

c) Appendix ZG describes pull test method for a threaded hole repair. With the aid of a labelled sketch, describe how this test is carried out. (3 Marks)

d) If the mine does not have a certificate of conformity for an item of Group I flameproof equipment, can the workshop overhaul it to the standard and supply a declaration that it is safe to use? Explain your answer. (2 Marks)

e) What do the following markings symbolise? (1 Mark)



f) What qualification must the 'responsible person' as defined on AS/NZS3800 for the workshop have? (1 Mark)

Question 11

Driven by safety and integrity

- Setting, upholding and monitoring the health and safety expectations by developing, supervising and following the safety management system

Protection

You are the new Manager of Electrical engineering at a mine site. Within your inspections over the first week, you find that numerous additions have been made to the infrastructure and no up to date power system studies can be found, additionally you find protection settings have been changed throughout the electrical plant with no due diligence applied.

a) What are your first actions? (2 Marks)

b) List four points that you would include in a scope of work for an external service provider to complete power system studies for the site. (4 Marks)

c) Work Health and Safety (Mines and Petroleum Sites) Regulation 2014 Clause 32 -Electrical safety

i. What form of protection is required to be installed on all circuits including sub circuits? (2 Marks)

ii. Except for circuits that are isolated from earth, or that have a supply voltage that is extra-low voltage, what other protection is required? (2 Marks)

Question 12

Effective Communication

- Explaining the results of their analysis of data, information and/or audit outcomes

Terminology

a) Define the following electrical protection related terms and acronyms: (10 Marks, 1 Mark for each question)

i. SIL

ii. IDMT

iii. VVVF

iv. KVAR

v. DGA

vi. ONAF

vii. BIL

viii. Buchholz protection

ix. Blocking protection

x. Draw power triangle and nominate phase angle, correctly label KW, KVAr, KVA.

End of Document